



ADAM Sp. z o.o.
NOISE & VIBRATION CONTROL

Morska 9A biuro@adam.com.pl
PL 84-230 Rumia adam.com.pl
tel. / fax. +48 58 / 671 38 35

SEISMIC HOUSE-KEEPING PAD ANCHOR,
SEISMIC ADHESIVE ANCHOR, SEISMIC WEDGE ANCHOR & SEISMIC ANCHOR STUD

HPA, SAA, SAB & SAS

DATA SHEET DS-212-1.1

7/16" (11mm) DIAMETER HOLE FOR #3 REBARS 12" (305mm) LONG to provide secondary anchorage and support main pad rebar

TAPERED DUCTILE IRON FITTING WITH HEX FACE FOR TIGHTENING (Self Locking in Concrete)

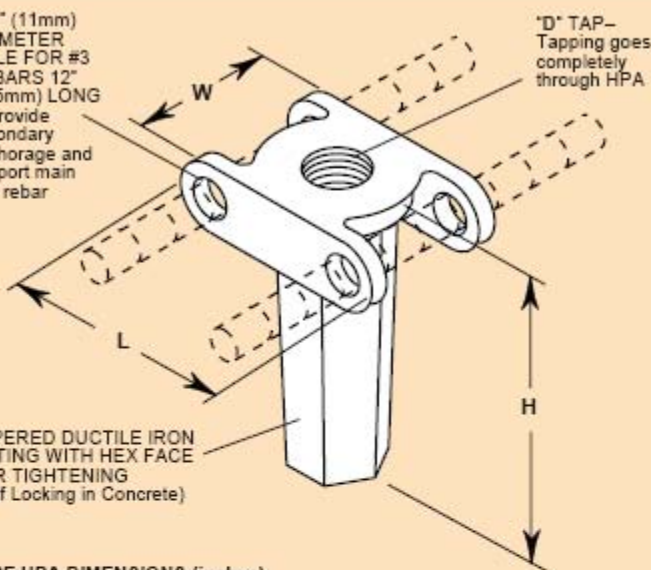

TYPE HPA DIMENSIONS (inches)

Size	L	W	H	D	SAS Stud Anchor Capacity in 3000 lb Concrete	
					Tension (lbs)	Shear (lbs)
HPA-1/2	21/8	11/4	3	1/2UNC	820	1540
HPA-5/8	23/8	11/2	3	5/8UNC	1210	2280
HPA-3/4	23/4	13/4	3	3/4UNC	1545	3675

TYPE HPA DIMENSIONS (mm)

Size	L	W	H	D	SAS Stud Anchor Capacity in 1361 kg Concrete	
					Tension (kgs)	Shear (kgs)
HPA-1/2	54	32	75	1/2UNC	372	699
HPA-5/8	60	38	75	5/8UNC	549	1025
HPA-3/4	70	44	75	3/4UNC	701	1667

A major cause of equipment restraint failure is the breaking up of housekeeping pads. Virtually all housekeeping pads are poured independently after completion of the structure. In many cases there is no mechanical attachment to the structural floor and the pad itself may not be reinforced.

The floor diaphragm vibrates vertically and under resonant conditions generates more than 1g. This tosses the pad and the machine attached to it. As the pad crashes back it breaks up and the equipment loses all anchorage.

Since housekeeping pad sizes and locations are not established until after a machine room floor is poured there is no way to cast in rebar pad stirrups. There is an undefined engineering area as to who should design and what type of cast in restraints should be used. In designing the HPA anchor system we have assumed the responsibility as part of our system certification.

The HPA anchor is manufactured in three sizes and has three anchoring capacities. The inverted hexagonal pyramid is self-locking in the housekeeping pad and has provision for passing 2 #3 rebars through the holes on top for positioning the pad reinforcement system. The number of anchors that are needed depend on the HPA size and the vertical rating of the SAS stud anchor as listed.

Primary Function Housekeeping Pad Anchor

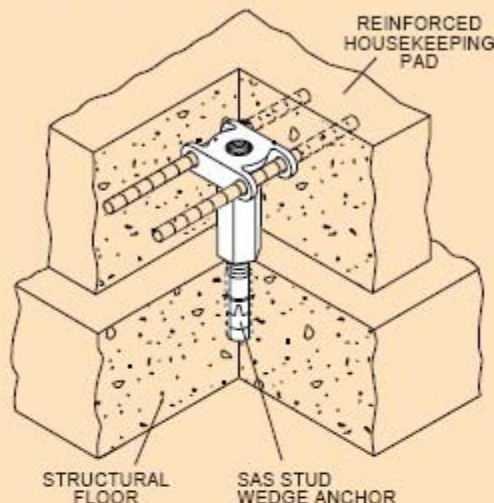

Housekeeping Pad and (Secondary Function) Sole Plate Anchor

THREADED ROD WITH NUT— Use two or more anchors per plate as required

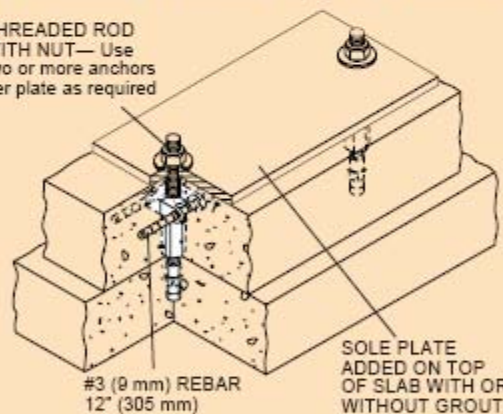

UPPER ATTACHMENT BOLT

LEVELING NUT

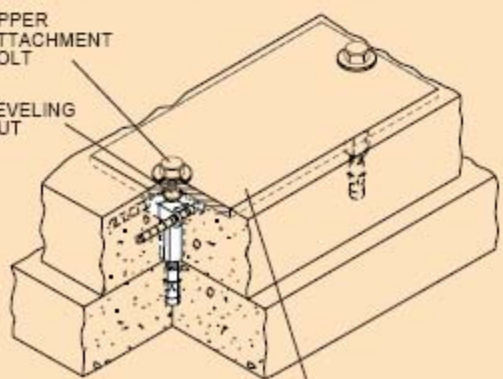

SOLE PLATE EMBEDDED IN CONCRETE TO REDUCE SHEAR ON ANCHOR BOLTS

If there are no overturning moments and we assume an upward force of 2g, the combined anchorage would equal the weight of the equipment plus the housekeeping pad. If there are vertical snubbers attached to the pad, HPA anchors should be clustered near that snubber.

Typical Pump Foundation

Housekeeping Pad 6' x 6' x 4" (1829 mm x 1829 mm x 102 mm)	= 1800 lbs. (816 kg.)
Pump & Motor	= 4000 lbs. (1814 kg.)
Concrete Inertia Base	= 2000 lbs. (907 kg.)
	<hr/>
	7800 lbs. (3537 kg.)

Assume 4 - 1500 lb. (680 kg.) equipment snubbers

Use 8 - 1/2" (13 mm) HPA

Use 4 - Additional 1/2" (13 mm) HPA down center of pad.

Installation Procedure

1. Lay out perimeter of housekeeping pad.
2. Drill 12- 1/2" (13 mm) holes in the structural floor 3" (76 mm) deep in the HPA locations shown on the drawing. If you hit rebar, shift the location.
3. Insert the 12- SAS 1/2" (13 mm) anchors and place a 1/2" (13 mm) standard washer over the stud.
4. Screw the small end of the HPA anchor on to the stud and tighten it hard with an adjustable or pipe wrench.
5. Insert the 12" (305 mm) long #3 (9 mm) rebars through the tops.
6. Tie the reinforcing bars in place as shown on the drawing.
7. Complete the forms and pour the housekeeping pad, preferably with isolator, snubber or equipment anchor bolts in place to avoid the need to drill in anchors.

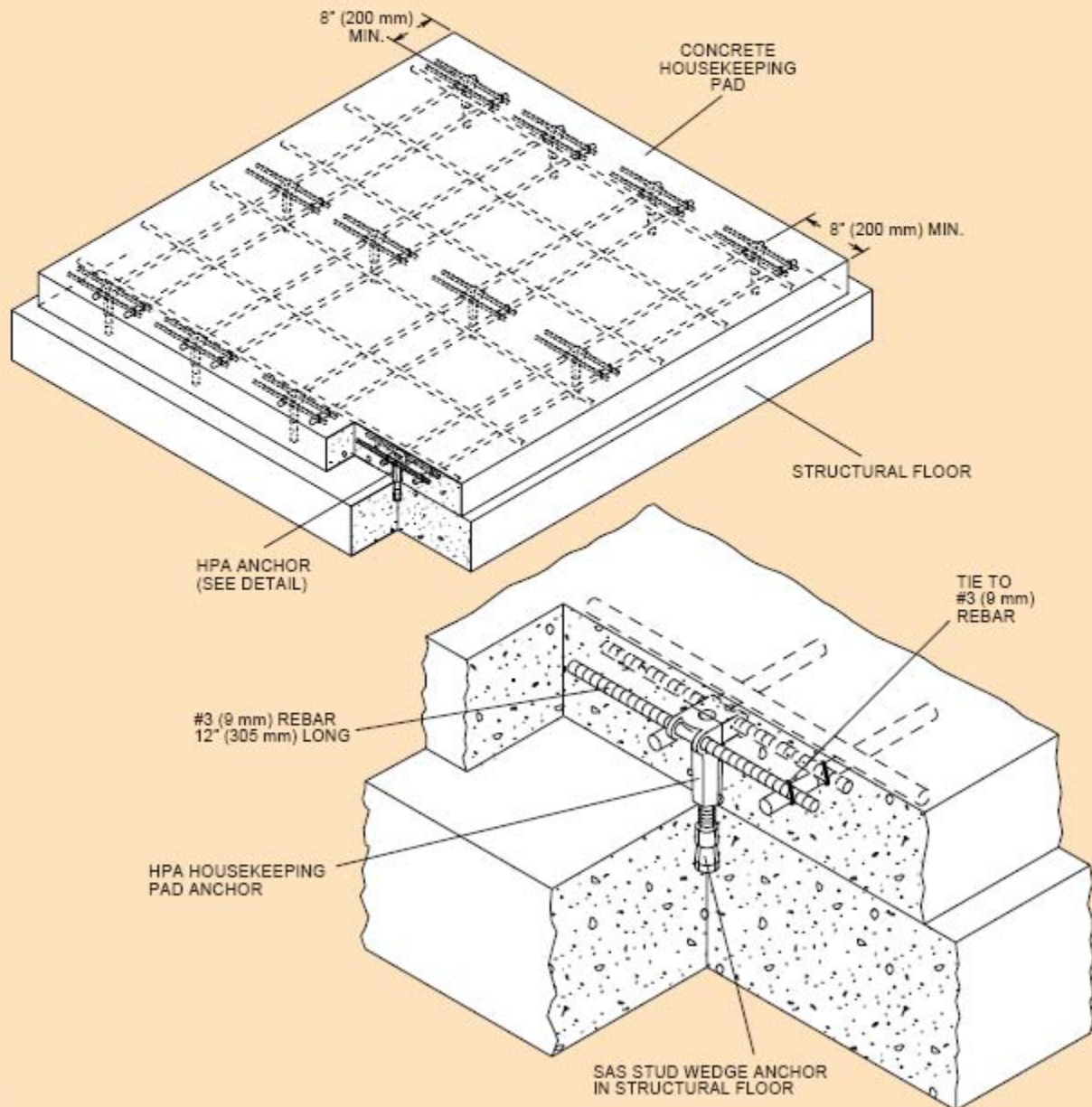

SAA, SAB & SAS

Anchorage of equipment in seismic zones is an important part of system restraint. When anchoring to concrete there are a variety of methods available. One excellent method is an Adhesive Anchor. It can be used in all non-overhead applications. An advantage is the lower reduction factors for closer spacings and edge distances. The style SAA Seismic Adhesive Anchor is a female anchor utilizing a cap screw to fasten to equipment. As with our style SAB anchor, equipment or restraints do not need to be lifted up and over studs for installation or removal. The SAA anchor is weather resistant and can even be installed in water filled holes.

Another excellent device is the wedge type expansion anchor. It provides the highest design load for the smallest hole size. Since it is load assisted, it provides excellent resistance to

vibration and shock loads. Its slip potential is actually a positive feature in seismic applications, giving early warning of potential failure whereas other anchors just fail catastrophically.

Mason offers two types of wedge anchors. Our SAB seismic anchor is a female wedge utilizing a cap screw to fasten to equipment. This design is for use with restrained mounts where periodic removal and inspection of the mounts may be required. The benefit is that it does not require lifting of mounts or equipment over a stud.

Mason's SAS seismic anchor stud is the same wedge design as the SAB seismic anchor. We offer this for suspension applications such as our SCB, seismic cable brace system, for use on piping and suspended equipment.

SAA-

Female Adhesive Seismic Anchor

"CS" CAP SCREW WITH STANDARD WASHER

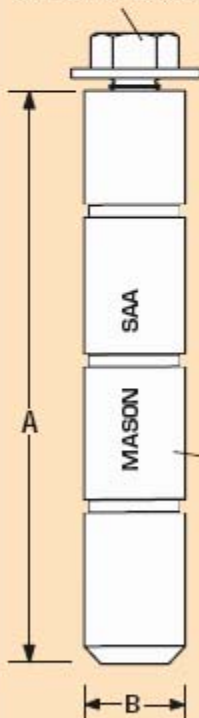

TYPE SAA FEMALE SEISMIC ANCHOR RATINGS (In normal weight concrete $F_c = 2500$ psi (17Mpa) min.)

Type & Size	Embedment (in) (mm)	Tension (lbs) (kgs) [†]	Tension with 33% Increase* (lbs) (kgs) [†]	Shear (lbs) (kgs) [†]	Shear with 33% Increase* (lbs) (kgs) [†]	Drill Bit Diameter (in) (mm)	Number of Anchors that can be installed per 22 oz Cartridge of Adhesive						
SAA-3/8	4	102	1560	708	2075	941	1100	499	1485	665	7/8	22	28
SAA-1/2	5	127	2840	1288	3775	1712	1960	889	2605	1182	1	25	19
SAA-5/8	6	152	4520	2050	6010	2726	3070	1393	4085	1853	1 1/8	29	13
SAA-3/4	7	175	5820	2645	7780	3527	4420	2009	5680	2672	1 1/8	29	11

TYPE SAA FEMALE SEISMIC ANCHOR DIMENSIONS

Type & Size	A (in) (mm)	B (in) (mm)	CS Capscrew (in) (mm)
SAA-3/8	4	102	3/4 19 3/8-16 UNC x 1 3/4 x44
SAA-1/2	5	127	7/8 22 1/2-13 UNC x 2 x51
SAA-5/8	6	152	1 25 5/8-11 UNC x 2 x51
SAA-3/4	7	175	1 25 3/4-10 UNC x 2 x51

CURE TIME FOR SAA ADHESIVE

Temperature (°F) (°C)	Cure Time (hours)	Bolt Up Time (hours)
40	4	48
65	18	36
70	21	24
80	26	12
100	37	6

ALL PARTS ELECTRO-PLATED

ALLOWABLE SPACING AND EDGE DISTANCE

Parameter	Critical Distance for Full Anchor Capacity	Minimum Distance for Reduced Anchor Capacity (in) (mm)	Reduction Factor
Distance Between Anchors	24D	8D	0.9
Edge Distances	Tension	SAA-3/8 1 3/4 44	0.7
		SAA-1/2 3 1/2 89	
	Shear	SAA-5/8 4 102	
		SAA-3/4 4 102	
	12D	4D	0.21

Anchor is ASTM A36, Capscrew is ASTM A307

[†]For Kn divide Kg by 102.

The load values above are multiplied by the reduction factor, when anchors are installed at the minimum distance listed. Use linear interpolation for spacing between critical and minimum distances.

*Loads may be increased 33% as allowed by code for seismic and wind loads. Tabulated loads are the lowest of either the bond strength, allowable steel strength for the anchor, or allowable steel strength of the capscrew. Anchors are to be installed in locations with an ambient temperature of 70°F (21°C). Contact Mason Industries if service temperature will vary ±35°F (±20°C) for reduction factor. Special inspection must be provided as described in the code. Anchor adhesive has ICBO report ER-5000.

For combined tension and shear forces on anchors, use the following equations: $(P_s/P_t)^{0.9} + (V_s/V_t)^{0.9} \leq 1.0$, where: P_s and V_s are Applied Forces and P_t and V_t are Allowable Forces

SAA anchor adhesive is easily applied with a special caulk gun.



SAB- Female Wedge Seismic Anchor

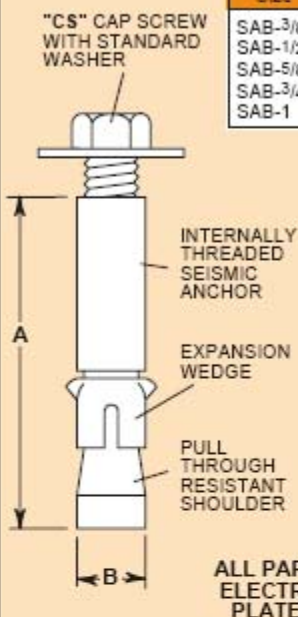

TYPE SAB FEMALE SEISMIC ANCHOR RATINGS Installed into 3000 psi (20 Mpa) concrete

Type & Size	Minimum Anchor Embedment (in) (mm)	Minimum Edge Distance (in) (mm)	Minimum Anchor Spacing (in) (mm)	Stone Aggregate Concrete				Lightweight Concrete	
				Tension* (lbs) (kg)†	Tension with 33% Increase** (lbs) (kg)†	Shear (lbs) (kg)†	Shear with 33% Increase** (lbs) (kg)†	Tension* (lbs) (kg)†	Shear (lbs) (kg)†
SAB-3/8	25/8 67	5 1/4 133	7 7/8 200	720 327	958 435	1050 476	1396 633	-	-
SAB-1/2	3 1/2 89	7 178	10 1/2 267	1010 458	1343 609	1830 830	2434 1104	800 363	1500 680
SAB-5/8	4 3/8 111	8 3/4 222	13 1/8 333	2220 1007	2953 1339	2970 1347	3950 1792	1625 737	2720 1234
SAB-3/4	5 1/4 133	10 1/2 267	15 3/4 400	2330 1057	3099 1406	3340 1515	4442 2015	-	-
SAB-1	5 3/4 146	11 1/2 292	17 1/4 438	3660 1524	4868 2207	6610 2998	8791 3987	-	-

*These tension values are applicable when the anchors are installed without special inspection as set forth in Section 1701.1 of UBC. When anchors are installed with special inspection as set forth in Section 1701.1 of the UBC, the tabulated values may be increased by 100%.

†For kN divide kg by 102

Notes: The tabulated values are for anchors installed at the specified spacings and edge distance. Spacings may be reduced by 87% provided the tension values are reduced to 50% (65% for SAB-1) and the shear values are reduced by 60%. Edge distances may be reduced by 50% provided the tension values are reduced by 30% and the shear values are reduced by 50%. Linear interpolation may be used for intermediate spacings.

For combined tension and shear forces on anchors, use the following equations:
 $(P_s/P_t)^{5/3} + (V_s/V_t)^{5/3} < 1.0$, where: P_s and V_s are Applied Forces
 and P_t and V_t are Allowable Forces

**Ratings may be increased 33 1/3% to accommodate periodic forces such as wind or seismic loads. Tabulated values include a safety factor of 8 to 1 for tension forces and 4 to 1 for shear forces.

For Stone Aggregate Concrete, refer to ICBO Report #ER-5063.
 For Lightweight Concrete, refer to Techmar report #TR-1193.

TYPE SAB FEMALE SEISMIC ANCHOR DIMENSIONS

Size	A (in) (mm)	B (in) (mm)	CS (in) (mm)
SAB-3/8	2 5/16 67	1/2 13	3/8"-16 UNC x 1 1/4 3/8"-16 UNC x 32
SAB-1/2	3 1/16 89	5/8 16	1/2"-13 UNC x 1 1/2 1/2"-13 UNC x 38
SAB-5/8	3 13/16 111	7/8 22	5/8"-11 UNC x 1 3/4 5/8"-11 UNC x 44
SAB-3/4	4 5/8 133	1 25	3/4"-10 UNC x 2 1/4 3/4"-10 UNC x 57
SAB-1	5 146	1 1/4 32	1"- 8 UNC x 2 1/2 1"- 8 UNC x 64

SAS- Male Wedge Seismic Anchor Stud

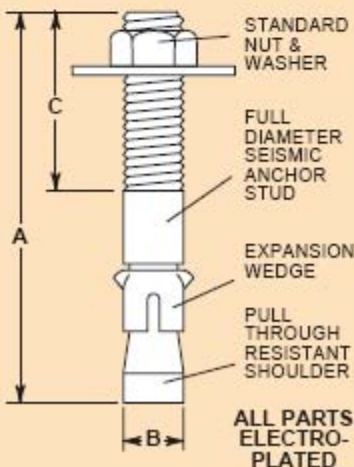

TYPE SAS SEISMIC ANCHOR STUD RATINGS

Type & Size	STONE AGGREGATE CONCRETE								LIGHTWEIGHT CONCRETE FILLED STEEL DECK	
	3000 psi (20 Mpa)				4000 psi (27 Mpa)				3000 psi (20 Mpa)	
	Tension* (lbs) (kg)†	Tension with 33% Increase** (lbs) (kg)†	Shear (lbs) (kg)†	Shear with 33% Increase** (lbs) (kg)†	Tension* (lbs) (kg)†	Tension with 33% Increase** (lbs) (kg)†	Shear (lbs) (kg)†	Shear with 33% Increase** (lbs) (kg)†	Tension* (lbs) (kg)†	Shear (lbs) (kg)†
SAS-3/8	325 146	435 198	765 347	1020 465	330 150	440 200	770 350	1027 467	300 136	1015 461
SAS-1/2	595 270	795 361	1540 699	2053 935	616 280	821 373	1565 711	2086 948	430 195	1260 573
SAS-5/8	885 402	1180 536	2260 1025	3013 1370	945 430	1260 573	2440 1110	3253 1479	525 238	1470 668
SAS-3/4	1095 498	1460 664	3650 1660	4866 2212	1095 498	1460 664	3650 1660	4866 2212	640 291	2010 914
SAS-1	-	-	-	-	4815 2184	-	-	-	-	-

*These tension values are applicable when the anchors are installed without special inspection as set forth in Section 1701.1 of the UBC or Section 1704 of the IBC. When anchors are installed with special inspection as set forth in Section 1701.1 of the UBC or Section 1704 of the IBC, the tabulated values may be increased by 100%.

†For kN divide kg by 102

Notes: The tabulated values are for anchors installed at the specified spacings and edge distances. Spacings may be reduced by 50% provided the shear and tension values are reduced by 40%. Edge distances may be reduced by 50% provided the tension values are reduced by 40% and the shear values are reduced by 50%. Linear interpolation may be used for intermediate spacings.

For combined tension and shear forces on anchors, use the following equations:
 $(P_s/P_t)^{5/3} + (V_s/V_t)^{5/3} < 1.0$, where: P_s and V_s are Applied Forces
 and P_t and V_t are Allowable Forces

**Ratings may be increased 33 1/3% to accommodate periodic forces such as wind or seismic loads. Ratings are from ICBO-ES Report 1821.

TYPE SAS SEISMIC ANCHOR STUD DIMENSIONS

Size	A (in) (mm)	B (in) (mm)	C (in) (mm)	Minimum Anchor Embedment (in) (mm)	Minimum Edge Distance (in) (mm)	Minimum Anchor Spacing (in) (mm)
SAS-3/8	5 127	3/8 10	1 1/4 32	3 76	4 1/2 114	9 229
SAS-1/2	5 1/2 140	1/2 13	1 1/2 38	4 102	6 152	12 305
SAS-5/8	7 178	5/8 16	1 3/4 44	5 127	7 1/2 190	15 381
SAS-3/4	8 1/2 216	3/4 19	2 51	6 152	9 229	18 457
SAS-1	9 229	1 25	2 1/4 57	6 3/4 171	10 254	20 508