



ADAM Sp. z o.o.

NOISE & VIBRATION CONTROL

Morska 9A biuro@adam.com.pl
 PL 84-230 Rumia adam.com.pl
 tel. / fax. +48 58 / 671 38 35

In 1976 the acoustical community asked us to develop a floating floor mounting that would last as long as the building and provide response frequencies lower than two inch (50mm) thick fiberglass.

We were pleased to find that Neoprene molded in exact accordance with DuPont formulations had addressed the life expectancy requirement as bridge supports. Outdoor applications are far more severe than within a building because of the temperature extremes, sunlight, rain, snow and ice.

We continued with Neoprene until 2006 when we developed Natural Rubber Compounds with the same life expectancy but much lower dynamic stiffness. These compounds are referred to as LDS. Frequencies in 2 inch (50mm) thickness are now 7 – 8 Hz compared to fiberglass @ 15 Hz. It is hard to understand why fiberglass is still acceptable. Please refer to Bulletin ACS-102-3, page 6 for a complete discussion.

In bridge and overpass work there is a need for very high loadings with pressures as high as 2000 lbs/square inch. If strain is limited to 10 to 15 percent of the pad thickness, both creep and permanent set are very acceptable.

Since we started by supporting floating floor areas of 1 square foot (0.1 square meters), our initial problem was to design a stable rubber column that would deflect 0.2 to 0.3 inches (5mm to 8mm) under minor loadings. A mounting thickness of 2 inches (50mm) at 10 to 15% deflection (strain) met the deflection criteria. A 2 inch (50mm) diameter reduced the shape factor (SF= Loaded Area/Perimeter Area) to achieve the low capacities of the EAFM-8823 on page 3.

All of the other sizes were gradually designed and tooled to raise or lower both capacities and frequencies.

In response to the wishes and specifications of Acousticians and Architects we almost always manufacture these products in Bridge Bearing Natural Rubber and tool for other sizes and thicknesses. We still supply Neoprene but only on special order.

This arsenal of available sizes encouraged other applications. Standard designs and variations are used as drop hammer shock absorbers, subway, railroad, building, pump and transformer isolators. We design and fabricate to virtually all requirements, including squares and rectangles with bonded embedded plates to increase shape factors.

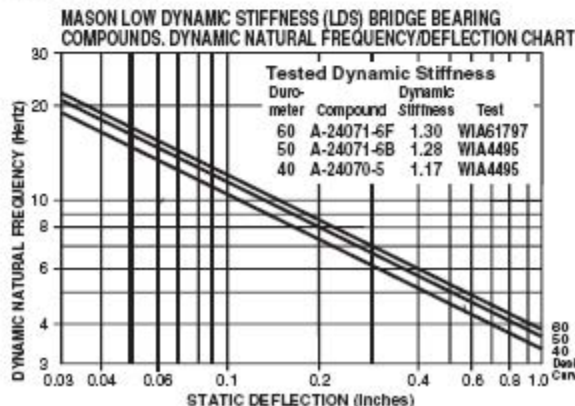

**ELASTOMERIC
 ACOUSTICAL
 FLOOR
 MOUNTINGS for
 FLOATING FLOORS
 and OTHER SUITABLE
 APPLICATIONS**

EAFM

EAFM-114-2 BULLETIN

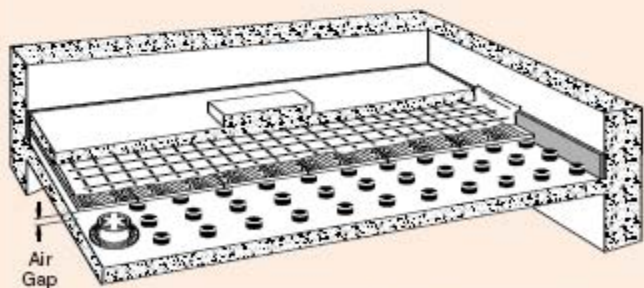

Typical EAFM Floating Floor

AASHTO BRIDGE BEARING SPECIFICATIONS FOR POLYISOPRENE

ORIGINAL PHYSICAL PROPERTIES			TESTED FOR AGING			OZONE	COMPRESSION SET	LONG TERM CREEP
Test: ASTM D-2240 & D-412	ASTM D-573		ASTM D-1149					
Duro-meter	Tensile Strength	Elongat. at Break	Hard-ness	Tensile Strength	Elongat. at Break	25 ppm in air by Vol. 20% Strain 100°F	ASTM D-395 22hrs/158°F Method B	ISO8013 168hrs
40±5*	2000 psi	500%	+10%	-25%	-25%	No Cracks	25%(max)	5%(max)
50±5	2250 psi	450%	+10%	-25%	-25%	No Cracks	25%(max)	5%(max)
60±5	2250 psi	400%	+10%	-25%	-25%	No Cracks	25%(max)	5%(max)
70±5	2250 psi	300%	+10%	-25%	-25%	No Cracks	25%(max)	5%(max)

*AASHTO does not spec 40 Duro. 40 Duro by Mason.

1/2" – 1" 13 – 25mm Height



EAFM 16114

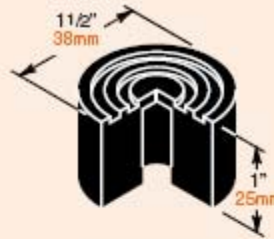

EAFM 6534

EAFM Designation & Color	Durometer ±5	0.025" 0.6mm Deflection		0.050" 1.3mm Deflection		0.075" 1.9mm Deflection		Temporary Overload* 3X Maximum Loading				
		lbs.	kgs.	Hz	lbs.	kgs.	Hz		lbs.	kgs.		
16114	Green 40	17	8	21.4	33	15	15.1	50	23	12.4	150	68
	Red 50	25	11	22.4	50	23	17.8	75	34	12.9	225	102
	White 60	37	17	22.5	73	33	16.0	110	50	13.0	330	150
		0.05" 1.3mm Deflection		0.1" 2.5mm Deflection		0.15" 3.8mm Deflection						
		lbs.	kgs.	Hz	lbs.	kgs.	Hz	lbs.	kgs.	Hz		
6534	Black 30	17	8	14.7	33	15	10.4	50	23	8.5	150	68
	Green 40	30	14	15.1	60	27	10.7	90	41	8.7	270	122
	Red 50	47	21	15.8	93	42	11.2	140	64	9.1	420	191
	White 60	70	32	16.0	140	64	11.3	210	95	9.2	630	286

*Temporary overload is often mentioned in specifications. We have tested mountings compressed to 50% of their initial thickness. After release there was no permanent set or damage.

1 1/2" 38mm Height

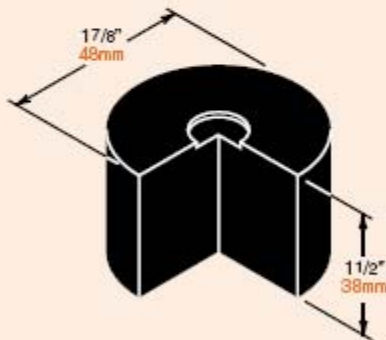

EAFM 8852

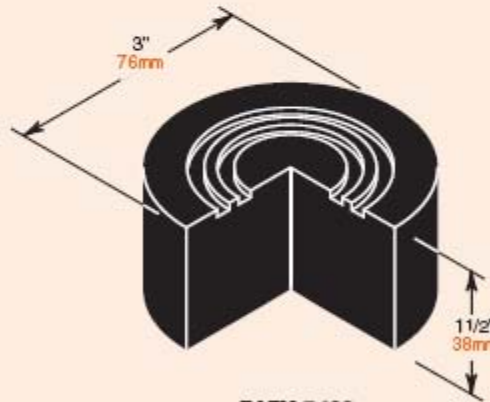

EAFM 7432

EAFM Designation & Color	Durometer ±5	0.075" 1.9mm Deflection		0.150" 3.8mm Deflection		0.225" 5.7mm Deflection		Temporary Overload* 3X Maximum Loading				
		lbs.	kgs.	Hz	lbs.	kgs.	Hz		lbs.	kgs.		
8852	Green 40	50	23	12.4	100	45	8.7	150	68	7.1	450	205
	Red 50	73	33	12.9	145	66	9.1	220	100	7.5	660	300
	White 60	113	51	13.0	225	102	9.2	340	155	7.6	1020	465
7432	Green 40	93	42	12.4	185	84	8.7	280	127	7.1	840	380
	Red 50	139	63	12.9	277	126	9.1	420	191	7.5	1260	570
	White 60	208	95	13.0	416	189	9.2	630	286	7.6	1890	860

*Temporary overload is often mentioned in specifications. We have tested mountings compressed to 50% of their initial thickness. After release there was no permanent set or damage.

2" 50mm Height

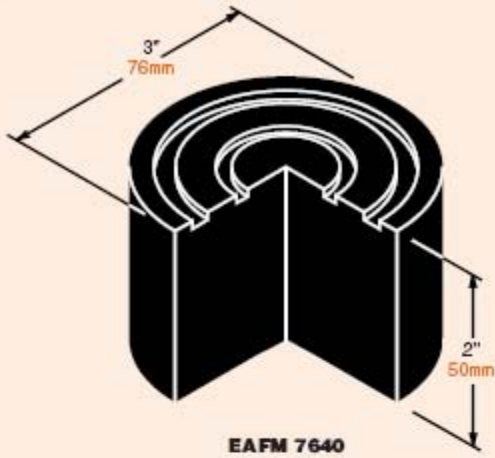
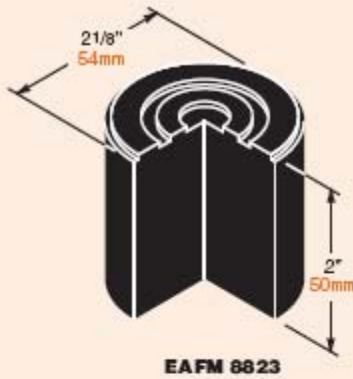

EAFM Designation & Color	Durometer ±5	0.1" 2.5mm Deflection			0.2" 5.1mm Deflection			0.3" 7.6mm Deflection			Temporary Overload* 3X Maximum Loading		
		Loading lbs.	kgs.	Frequency Hz	Loading lbs.	kgs.	Frequency Hz	Loading lbs.	kgs.	Frequency Hz	lbs.	kgs.	
8823	Green	40	48	22	10.7	97	44	7.6	145	66	6.2	435	197
	Red	50	80	36	11.2	160	73	7.9	240	109	6.4	720	327
	White	60	120	54	11.3	240	109	8.0	360	163	6.5	1080	490
7640	Green	40	140	64	10.7	280	127	7.6	420	191	6.2	1260	572
	Red	50	200	92	11.2	400	181	7.9	600	272	6.4	1800	816
	White	60	300	136	11.3	600	273	8.0	900	409	6.5	2700	1225

*Temporary overload is often mentioned in specifications. We have tested mountings compressed to 50% of their initial thickness. After release there was no permanent set or damage.

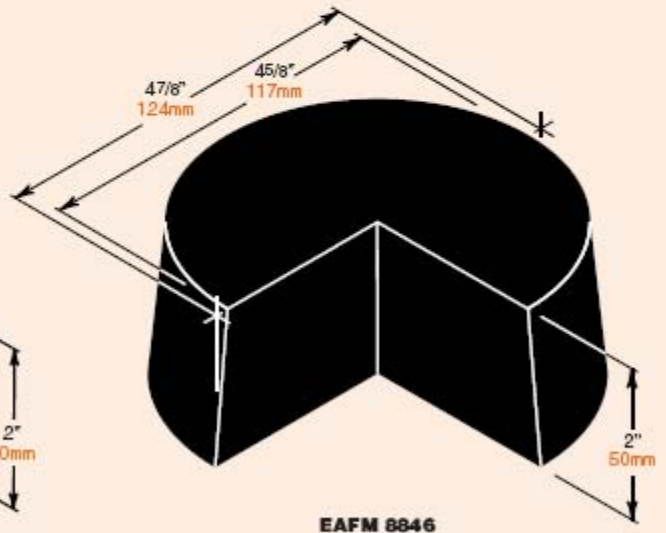
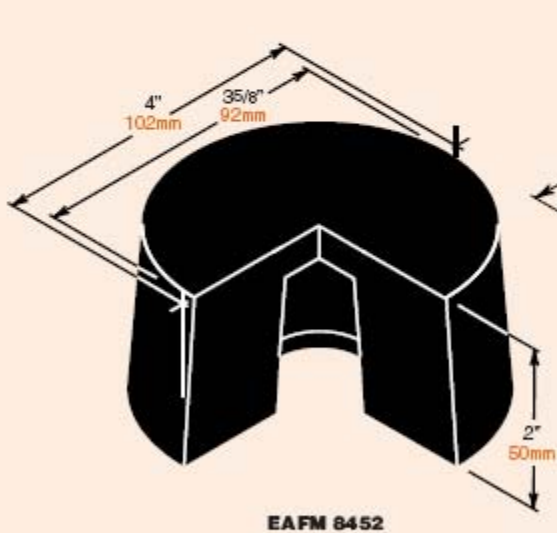

EAFM Designation & Color	Durometer ±5	0.1" 2.5mm Deflection			0.2" 5.1mm Deflection			0.3" 7.6mm Deflection			Temporary Overload* 3X Maximum Loading		
		Loading lbs.	kgs.	Frequency Hz	Loading lbs.	kgs.	Frequency Hz	Loading lbs.	kgs.	Frequency Hz	lbs.	kgs.	
8452	Green	40	167	76	10.7	333	151	7.6	500	227	6.2	1500	681
	Red	50	256	116	11.2	513	233	7.9	770	350	6.4	2310	1050
	White	60	400	182	11.3	800	364	8.0	1200	545	6.5	3600	1636
8846	Red	50	600	273	11.2	1200	545	7.9	1800	818	6.4	5400	2454
	White	60	900	409	11.3	1800	817	8.0	2700	1227	6.5	8100	3681

*Temporary overload is often mentioned in specifications. We have tested mountings compressed to 50% of their initial thickness. After release there was no permanent set or damage.

2" 50mm Nominal Height

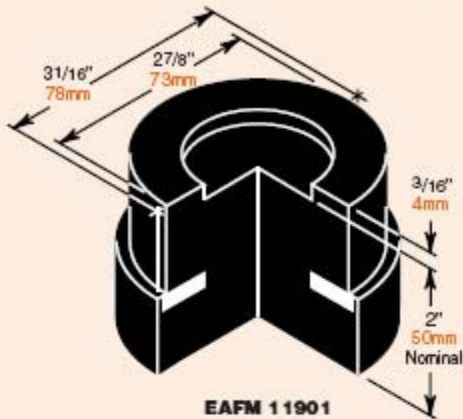

EAFM 11901

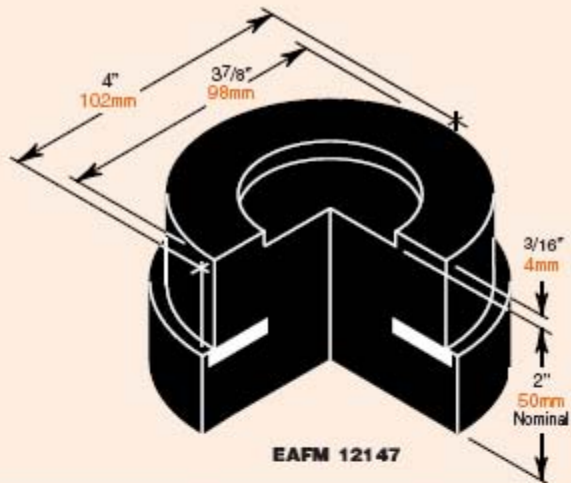

EAFM 12147

EAFM Designation & Color	Durometer ±5	0.1" 2.5mm Deflection		0.2" 5.1mm Deflection		0.3" 7.6mm Deflection		Temporary Overload* 3X Maximum Loading		
		Loading lbs. kgs.	Frequency Hz	Loading lbs. kgs.	Frequency Hz	Loading lbs. kgs.	Frequency Hz	lbs. kgs.		
11901 Red	50	368	167	735	333	1100	499	6.4	3300	1497
	60	520	236	1040	472	1550	703	6.5	4650	2109
12147 Red	50	667	303	1335	606	2000	907	6.4	6000	2722
	60	1075	488	2150	975	3200	1451	6.5	9600	4354

*Temporary overload is often mentioned in specifications. We have tested mountings compressed to 50% of their initial thickness. After release there was no permanent set or damage.

3" 76mm Height

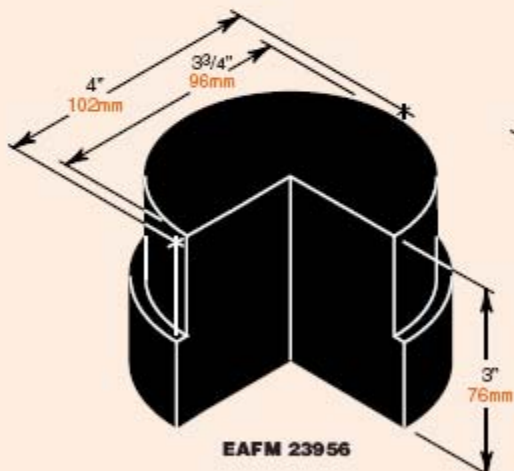

EAFM 23956

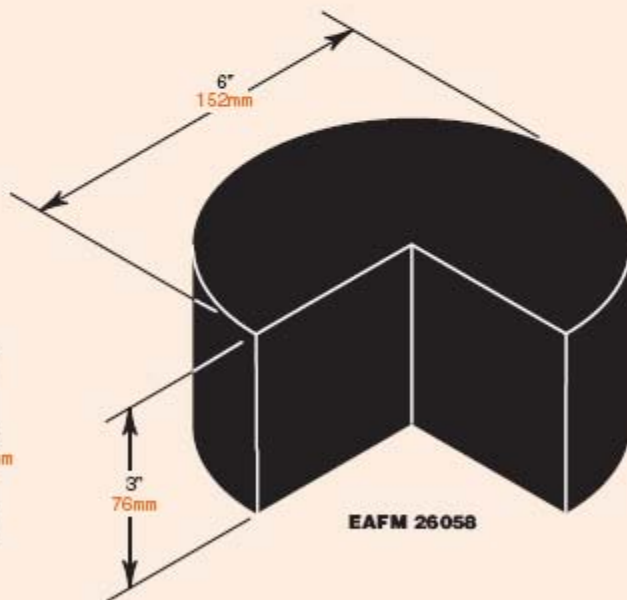

EAFM 26058

EAFM Designation & Color	Durometer ±5	0.15" 3.8mm Deflection		0.3" 7.6mm Deflection		0.45" 11.4mm Deflection		Temporary Overload* 3X Maximum Loading		
		Loading lbs. kgs.	Frequency Hz	Loading lbs. kgs.	Frequency Hz	Loading lbs. kgs.	Frequency Hz	lbs. kgs.		
23956 Green	40	290	105	460	210	700	320	5.0	2100	960
	50	365	166	730	332	1100	500	5.2	3300	1500
	60	500	227	1000	454	1500	680	5.3	4500	2040
26058 Green	40	270	125	540	250	810	375	5.0	2430	1125
	50	750	340	1500	680	2250	1020	5.2	6750	3060
	60	950	430	1900	860	2850	1290	5.3	8560	3870

*Temporary overload is often mentioned in specifications. We have tested mountings compressed to 50% of their initial thickness. After release there was no permanent set or damage.